

## 2nd Order All-Pass Prototype

### A post modern filter theory design approach

Rick Campbell January 2016

Consider the network shown here. It has unequal differential drive, with lower ac voltage source 1 volt and upper ac voltage source K volts. The outputs at i and q are nodes with infinite external load impedance. Capacitors are in Farads, resistors are in ohms, and the network is characterized by three variables, a, K and m.

K and a are related by the expression:

$$K = 1 + 4a$$

$$a = \frac{K - 1}{4}$$

which sets the output voltages at i and q = 1 across a wide bandwidth.

Having set the output voltage to 1, the output phase changes in a nearly straight line with slope set by the value a. A steeper slope, for larger values of a, requires a narrower frequency range between the top of the linear portion of the phase curve and the bottom.

After setting the output to 1 volt and the bandwidth of the linear phase by choosing a, we design a second q network shifted on the frequency axis such that the phase difference between the output of the i and q networks is approximately 90°. The shifting variable m may be obtained from a by first calculating the intermediate variable M:

$$M = \frac{1 + 2a}{a}$$

Then multiply M by a constant between 1.084 and 1.088, for example:

$$m = 1.086M$$

A family of 8 all-pass filters with a from 0.50 to 0.80 achieve ideal opposite sideband performance with m between 1.084M and 1.088M. In the simulator, set the phase of the voltage sources in the q network as a parameter stepped between -90 to +90 degrees. Then plot the output as V(i) + V(q).

It is possible to iterate m in tiny steps to obtain an ideal, symmetrical opposite sideband response at exactly 90.00 degrees in the simulator. In practice, design the network using the average constant 1.086, scale to the desired impedance and frequency, choose nearest 0.1% resistor values, and then use the receiver or transmitter phase trim to correct for the small variation in m.

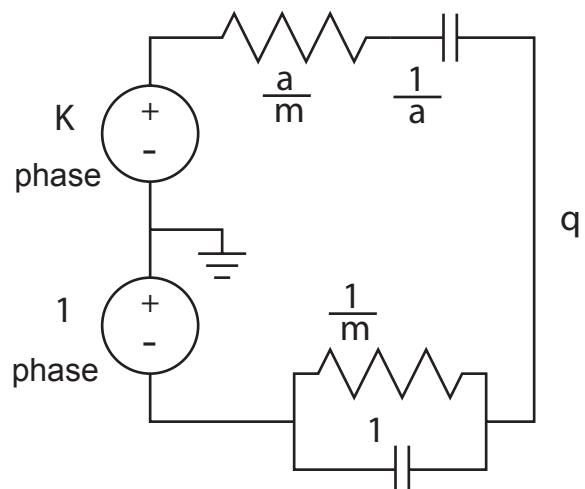
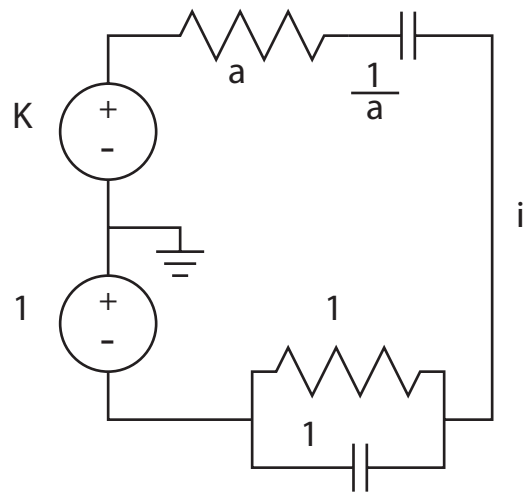

As a design exercise, reverse engineer the 2Q4. Calculate the values of a, K and m for the classic B&W 350 2Q4 network, shown here.

The variable a is the ratio of any pairs from the all-pass prototype. Three values for a are available from the 2Q4 network:

- 0.6325
- 0.6324
- 0.6313

This illustrates tolerances in this network, and the average value of a is 0.632

From a, we can calculate K, the required ratio of unequal differential drive voltages:

$$K = 1 + 4a = 3.528$$

Note that in the original 2Q4 application notes, the drive ratio is specified as approximately 7 to 2 = 3.50.

Next, calculate the value M from the average a, and the value of m from the 2Q4 network ratios.

$$M = \frac{1 + 2a}{a} = 3.582$$

and m using the ratio of the 2Q4 i and q resistor pairs is:

- 3.896
- 3.889

The relationship between the average a values and m is 1.087M. Note that 4 or 5 significant figures permit ideal responses in the simulator, but are unrealistic in practice.

All-pass prototype i q networks have been simulated for values of a from 0.50 through 0.80 with promising results, tabulated on the next page. Networks with a below .632 have wider bandwidths than the 2Q4, less critical tolerances, and suppression between 33 and 36 dB. The a = 0.80 network has bandwidth 3.41, suppression greater than 60 dB, with tolerances unlikely in practice.

As with any Modern Filter Theory prototype networks, the all-pass prototypes at 1Ω and angular frequency ω = 1 may be scaled to any other impedance and frequency range by simply scaling all the component values. Working backward using the 2Q4 as an example, the 1Ω resistor has been scaled to 770k. To scale resistors, multiply by the scale impedance. Since capacitors have lower impedance at higher frequency, the 1 Farad capacitors in the all-pass prototype are impedance scaled by dividing by 770k. Finally, scale the frequency by dividing the capacitor values by an angular frequency. The 1 farad capacitor in the prototype scales to 430pF in the 2Q4. The 2Q4 angular frequency is 3.03x10<sup>3</sup>, and f is around 500 Hz. Check values with a circuit simulator.

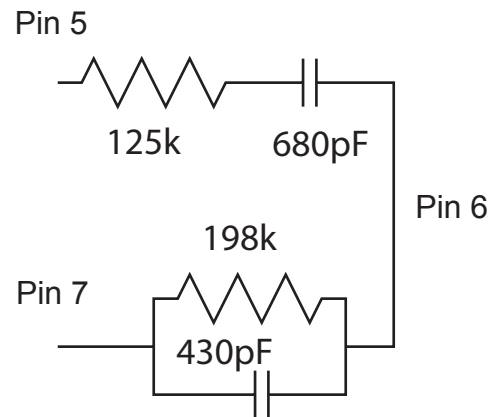
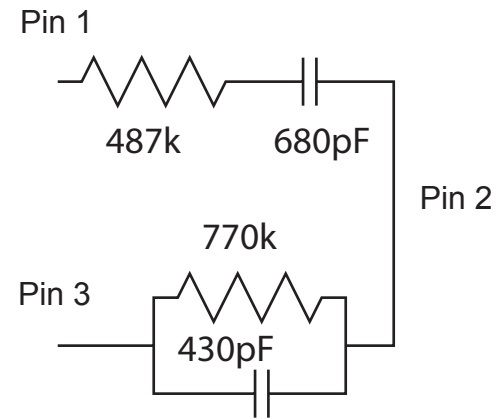

# A family of All-Pass Prototypes

Rick Campbell

10 January 2016

Table 1 includes stepped values for the resistor scaling value  $a$ , calculated values for the resulting voltage ratio  $K$  and  $i$   $q$  network scaling parameter  $M$ , along with values of  $m$  taken from simulations, where  $m$  has been adjusted from calculated  $m = 1.086M$  in a circuit simulator to obtain symmetrical opposite sideband suppression. Total adjustment of  $m$  is within the range 1.084M to 1.088M.

Parameter  $a$  sets the bandwidth over which the network provides maximum opposite sideband suppression, defined as:

$$BW = \frac{\text{Upper frequency band limit}}{\text{Lower frequency band limit}}$$

For example, the 2Q4 network has  $BW = 9.02$ . If the lower frequency band limit is 300 Hz, then the upper frequency band limit is 2700 Hz. Values for  $BW$  were obtained from the simulator.

Parameter  $m$  is varied in the simulated suppressed opposite sideband frequency band for symmetrical response with 3 equal amplitude peaks, at exactly 90 degree phase shift. The resulting suppression value at the three peaks is listed in the table.

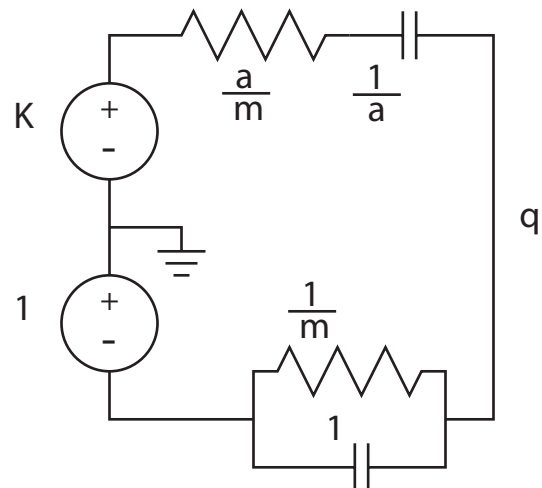
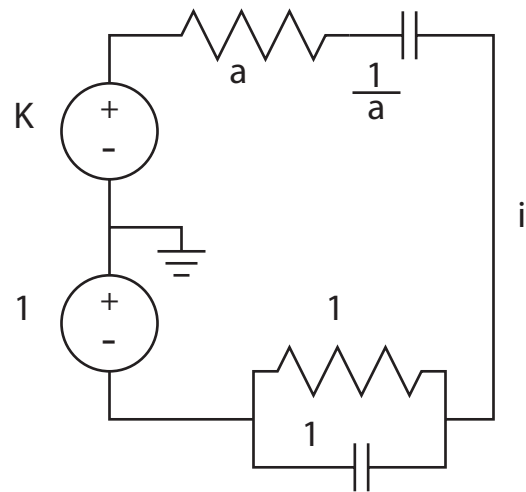

	$a$	$K$	$M$	$m$	$BW$	Suppression
	0.50	3.00	4.000	4.345	19.7	33dB
	0.55	3.20	3.818	4.140	14.1	35dB
	0.60	3.40	3.667	3.985	10.8	39dB
2Q4	0.632	3.528	3.582	3.895	9.02	41dB
	0.65	3.60	3.538	3.850	8.32	42dB
	0.70	3.80	3.429	3.730	6.50	46dB
	0.75	4.00	3.333	3.620	4.75	51dB
	0.80	4.20	3.250	3.541	3.41	60dB

Note that symmetrical suppression greater than 41 dB across the opposite sideband is difficult to maintain in practice with real components when these networks are imbedded in electronic circuits.